

Features

- ±2000V galvanic isolated
- ±5000V Surge protection
- Multiple measurement ranges
- Non-polarized power supply
- Low-power consumption
- DIN rail mounting

Advantages

- Multiple ranges from ±3mA to ±100A
- Various output voltage options
- DC-100kHz bandwidth
- Accuracy up to ±0.1%

Applications

- EV and new energy testing
- Current monitoring
- Power analysis

Description

IsoCap-ST is a galvanic isolated current sensor that can measure voltage from ±3mA to ±100A, providing a

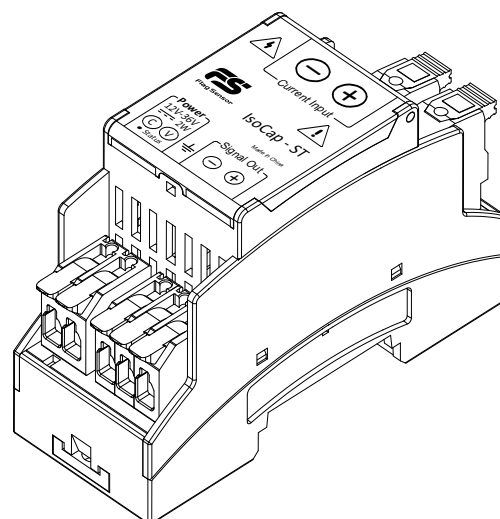

cost-effective solution for current measurement. In addition, IsoCap-ST has multiple measurement ranges selection, it can be customized for specific requirement. IsoCap-ST has many advantages, such as small size, high precision, and DIN rail mounting.

Specifications

Electrical				
Parameter	Test conditions	Minimum	Typical values	Maximum
Input ranges		±3mA		±100A
Accuracy	@ 25°C		±0.1% of range or ±0.2% of range	
Bandwidth (-3dB)			DC-100kHz	
Nonlinear error				0.03%
Maximum dela				5us
Output offset voltage	@ 25°C	-1mV		1mV
Output voltage			±5V differential pair or ±10V differential pair or customized	
Common mode rejection ratio (@ 50Hz)	@ 25°C		100dB	
Phase shift (@ 50Hz)	@ 25°C			0.05°
Power supply voltage		12V	24V	36V
Power supply power		2W		

Typical ranges of IsoCap-ST (other ranges can be made on demand)								
±3mA	±10mA	±50mA	±500mA	±1A	±5A	±10A	±50A	±100A

Insulation parameter	
Primary and secondary isolation voltage	>±2000V
Withstand common mode surge voltage (1min)	±5000V
Insulation resistance	>10GΩ

Environmental and mechanical characteristics	
Operation temperature	-15°C ~ 70°C
Storage temperature	-25°C ~ 80°C
Weight	78g
Mounting type	DIN rail mounting / wall mounting
Number of channels	1 channel
Hot swapping	Not supported

Block Diagram

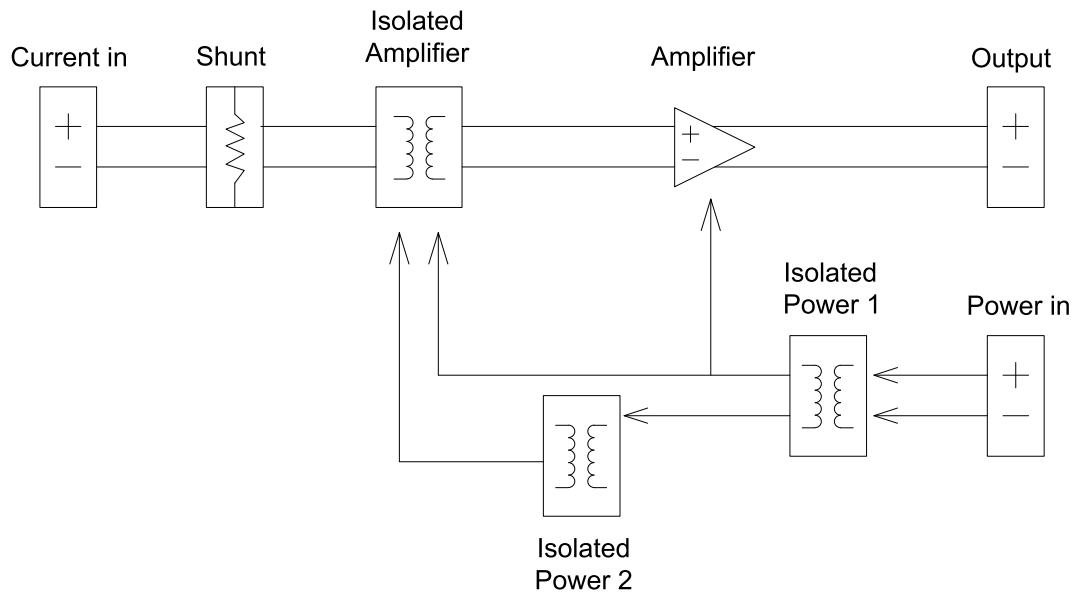

IsoCap-ST block diagram

The IsoCap-ST uses the shunt to measure current flowing through input conductor. The isolated amplifier transfers the induced voltage on shunt from primary to secondary. The amplifier at the output side converts it to ±5V or ±10V differential voltage. The above diagram shows the signal processing in general.

Testing Setup

1. Connect the output voltage to the DAQ/instrument, the ground must be well grounded.
2. Connect DC power supply to power it on.
3. Connect the measurement current to the input, make sure the tested current source is off before connecting.
4. Turn the tested current source on.

Disassemble

Ensure that the tested current source is turned off, then remove the tested current wire. Disconnect the sensor from power, and remove the output and grounding wires.

Dimensions (in mm)

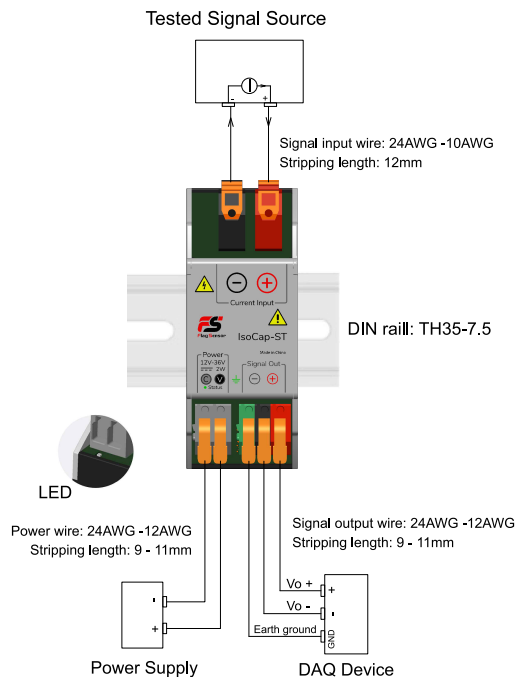
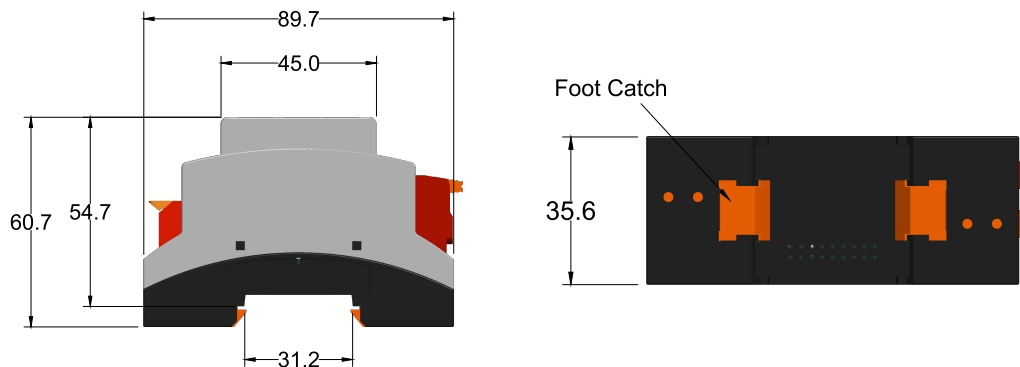

Ordering Code

Product name	Input ranges	Output voltage	Accuracy
IsoCap-ST	$\pm 3\text{mA} \sim \pm 100\text{A}$	$\pm 5\text{V}$ or $\pm 10\text{V}$	$\pm 0.1\%$ (A) or $\pm 0.2\%$ (B)

E.g. **IsoCap-ST-3mA-5-A** (3mA: input range is $\pm 3\text{mA}$, 5: output voltage is $\pm 5\text{V}$, A: accuracy of $\pm 0.1\%$ of range).

If you have queries regarding the IsoCap-ST or require specifications outside standard ranges, please do not hesitate to contact us.

CAUTION

Do not connect or disconnect sensor or test leads in operation.

To avoid fire or shock hazard, observe all ratings and markings on the product carefully.

If you suspect there is damage to this product, have it inspected by qualified service personnel.

Do not touch exposed connections and components in operation.

Do not operate in wet/damp conditions.

Do not operate in an explosive atmosphere.

Keep product surfaces clean and dry.

Warning

The service instructions are for use by qualified personnel only. To avoid personal injury, do not perform any servicing unless you are qualified to do so. Refer to all safety contents prior to performing service.