

## Features

High precision  
 Passive probe  
 Standard BNC output connector  
 Portable

## Advantages

1000:1 divider ratio  
 DC - 110MHz bandwidth  
 25kV DC / 30kV peak  
 DC, AC and Pulse compatible  
 Accuracy up to  $\pm 0.15\%$

## Applications

Power supply design  
 Power semiconductors  
 Switch mode control  
 Power converters  
 Lightning surge  
 Voltage monitoring

## Description

The PVD-25 is a type of wideband voltage divider

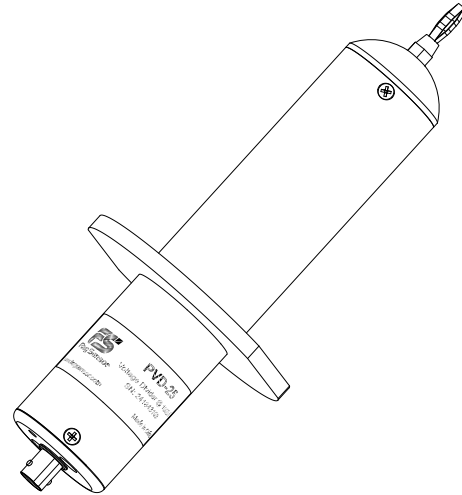

which is designed to measure single-ended high voltage. The PVD-25 can measure multiple single-ended signal such as DC, AC and pulse. The PVD-25 scaled down its input signal and outputs low voltage, which can easily be processed by universal instruments, such as oscilloscope, digital multimeters, etc. You can measure DC voltages up to 25 kV RMS and pulses up to 30 kV peak. The 110 MHz bandwidth enables you to measure fast, high-voltage signals.

## Specifications

| Electrical               |                 |         |                |                |
|--------------------------|-----------------|---------|----------------|----------------|
| Parameter                | Test conditions | Minimum | Typical values | Maximum        |
| Standard Divider Ratio   |                 |         | 1000 : 1       |                |
| Max Peak Voltage (DC,AC) |                 |         | 25kV           |                |
| Max Peak Voltage (Pulse) |                 |         | 30kV           |                |
| Accuracy (DC - 2 Hz)     | @ 25°C          |         |                | 0.15% of range |
| Accuracy (2Hz - 200Hz)   | @ 25°C          |         |                | 1.5% of range  |
| Accuracy (200Hz - 5MHz)  | @ 25°C          |         |                | 2% of range    |
| Accuracy (> 5MHz)        | @ 25°C          |         |                | 5% of range    |
| Bandwidth (-3dB)         |                 |         | DC-110MHz      |                |
| Nonlinear error          |                 |         |                | 0.022%         |
| Rise time                |                 |         | 3ns            |                |
| Input Impedance          |                 |         | 300MΩ / 8pF    |                |
| Input Signal Type        |                 |         | single-ended   |                |
| Output Signal Type       |                 |         | single-ended   |                |

| Environmental and mechanical characteristics |                 |
|--|-----------------|
| Operation temperature                        | -15°C ~ 70°C    |
| Storage temperature                          | -25°C ~ 80°C    |
| Input connector                              | 4mm Banana plug |
| Output connector                             | BNC (jack)      |
| BNC cable length                             | 4.5m            |

## Block Diagram

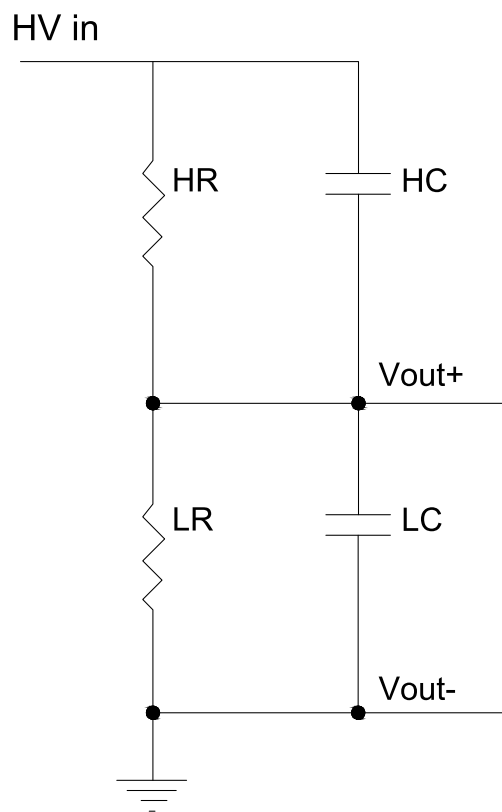

**PVD-25 block diagram**

The PVD-25 consists of a high voltage network represented by a parallel capacitor and resistor, and a low voltage network which consists of a parallel RC network. The input high voltage will be attenuated by 1000 times, and output low voltage which can be processed by instrumentations.

## Testing Setup

1. Connect the output voltage to the instrument, e.g. oscilloscope or digital multimeter, the ground must be well grounded.
2. Connect the measurement voltage to the input, make sure the tested voltage is off before connecting.
3. Turn the tested voltage on.

## Disassemble

Ensure that the tested voltage source is turned off, then remove the tested voltage wire. Finally, remove the output and grounding wires.

### Remark:

1. The oscilloscope should be grounded to safety ground. A 1.111 M $\Omega$  resistance can parallel with digital multimeter (10 M $\Omega$  input) to produce a 1 M $\Omega$  input impedance.
2. In general, the PVD-25 has a derating characteristic when measuring high frequency AC signal, due to heating in AC dielectric loss and capacitive ESR.
3. The input pulse should not be too high in frequency and too long in duration, when the amplitude of pulse is up to max peak voltage.
4. When DC voltage applied, PVD-25 should not have a derating phenomenon.

## Dimensions (in mm)

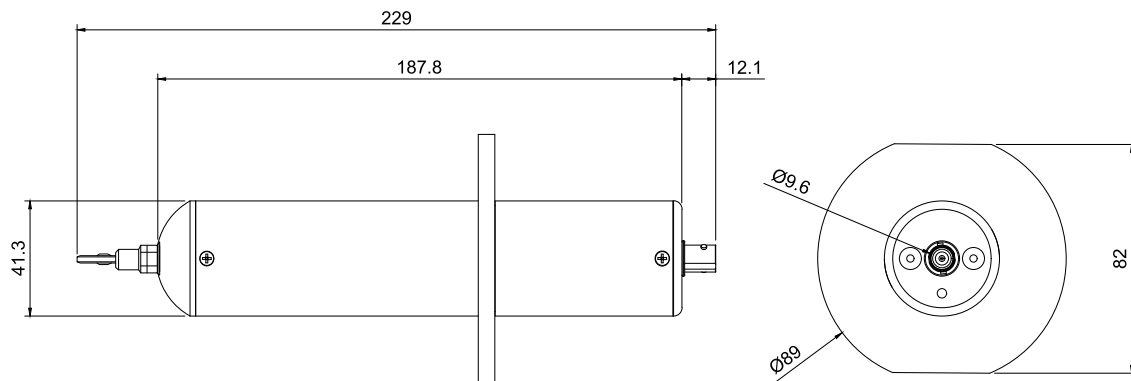

PVD-25 Driving Oscilloscope

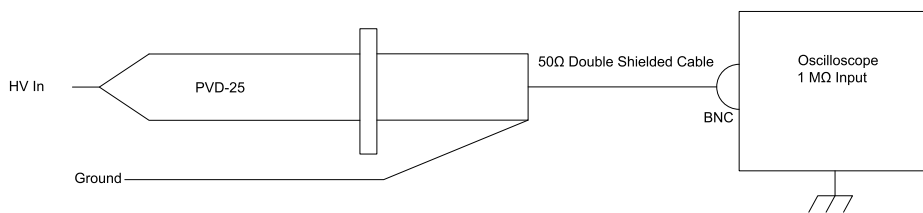

PVD-25 Driving Meter

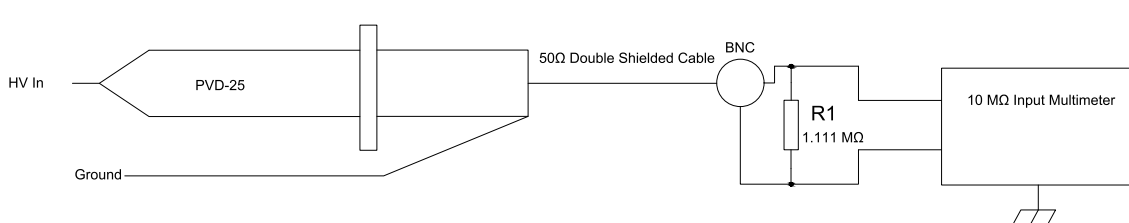

## Ordering Code

E.g. **PVD-25**

If you have queries regarding the PVD-25 or require specifications outside standard ranges, please do not hesitate to contact us.

### **CAUTION**

Do not connect or disconnect sensor or test leads in operation.

To avoid fire or shock hazard, observe all ratings and markings on the product carefully.

If you suspect there is damage to this product, have it inspected by qualified service personnel.

Do not touch exposed connections and components in operation.

Do not operate in wet/damp conditions.

Do not operate in an explosive atmosphere.

Keep product surfaces clean and dry.

### **Warning**

The service instructions are for use by qualified personnel only. To avoid personal injury, do not perform any servicing unless you are qualified to do so. Refer to all safety contents prior to performing service.